

TECHNISCHE FOCUS OP DE **HVS** STALMESTSTROOIERS

Technische gids voor de juiste aankoop



Lebowitch

HVS STALMESTSTROOIERS

ALL-TERREIN VERLAAGDE MACHINES VOOR DE BERGEN

Standaard  of optionele uitrusting 

 170 of 191 cm afhankelijk van het model



130 of 150 cm afhankelijk van het model

Monoblok, wijd uitlopende laadbak met zijwanden uit één stuk voor het eenvoudig lossen van goederen.

 **Frontverhoogsel** met zelfreinigend rooster.



 **Bescherming met 2-componentenlak (2K industriële kwaliteit)**

(A) Laadbak van ST420 staalplaat met hoge elasticiteitsgrens (dikte: 4 mm).

(B) Korrelstralen.

(C) Laag 2K primer direct aangebracht na het stralen + flash-off voor het aanbrengen van de finish.

(D) Afwerking met 2K verf en een gehamerd effect.



 **Hydraulische installatie** met elektrische bediening. 120 l tank voor HVS 37S08 en 42S09, en 140 l tank voor andere modellen.

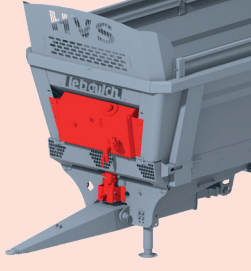

 **Elektrohydraulisch systeem** beschermd onder de laadbak.



 **Documentenbuis** met geïndividualiseerd onderdelenboek.



 **Wielblokken**



 **Keuze aan trekogen**

(A) Vastgebout Ø 50 mm (standaard)

(B) Vastgebout kogelscharnierroog (optie)



 **Grote keuze aan banden**

- Ø 1 550 tot 2 060 mm
- Breedte: 467 tot 680 mm
- Banden van de grootste merken **BKT** **ALLIANCE** **Mitas**



460/85R34 520/85R38 580/70R38 620/75R26 650/85R38



En nog veel meer!

 **Hydraulische steunpoot** met handpomp.





 **In hoogte verstelbare geveerde dissel** (behalve modellen 37S08 en 42S09).

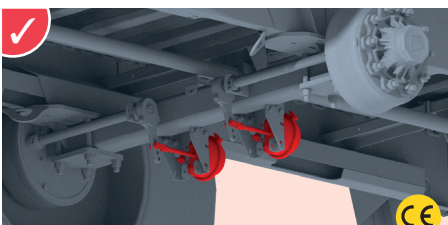

 **Luchtremmen** 



 **Hydraulische remmen** 

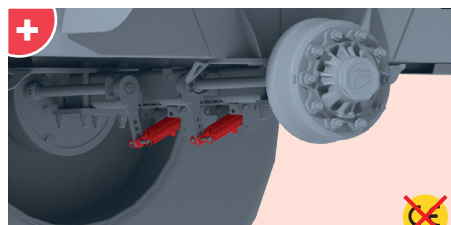

 **Gecombineerd remsysteem** (hydraulische en luchtremmen) 



 **Aandrijflijn met overbrenging onder de verlaagde as** (ideaal voor hellingen). Slijtringen op achterste lagers. Vrijloop op achterste cardankoppeling. Afdichtingsmanchet vooraan en op de strooitafel.

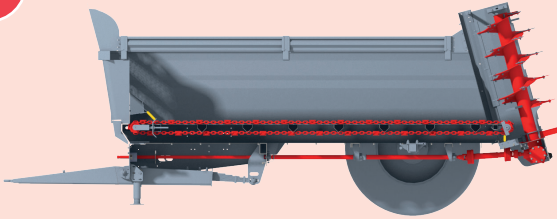

 **Groothoektafak** met nokkenbeveiliging en **slanghouder** met instelbare lengte en hoek.



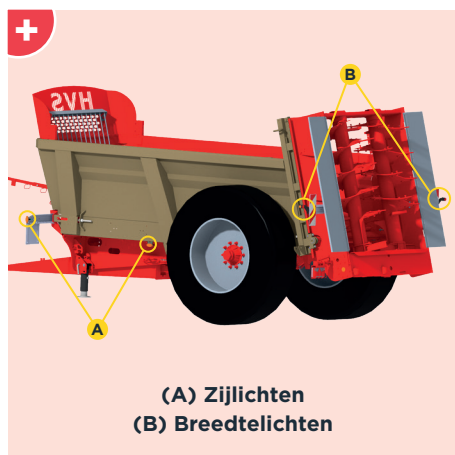
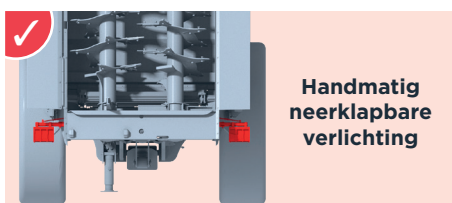
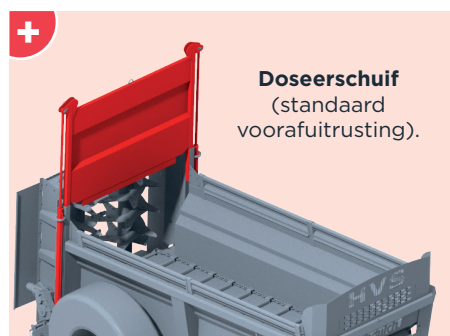
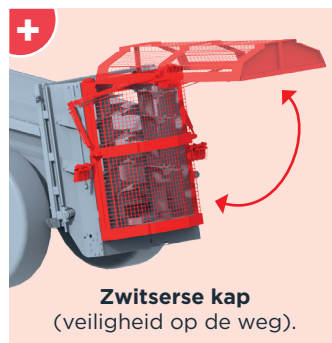
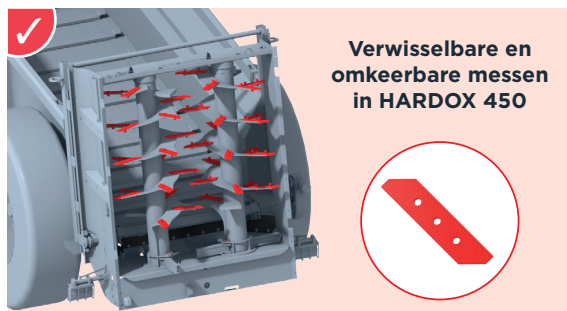
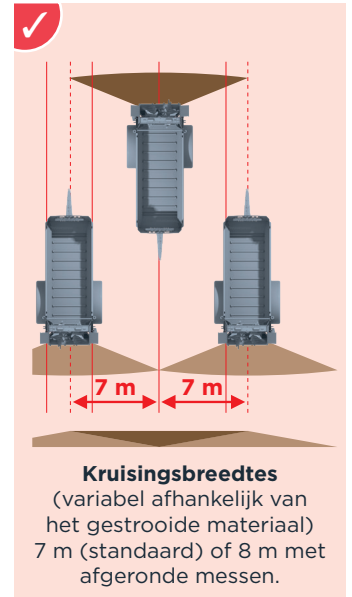
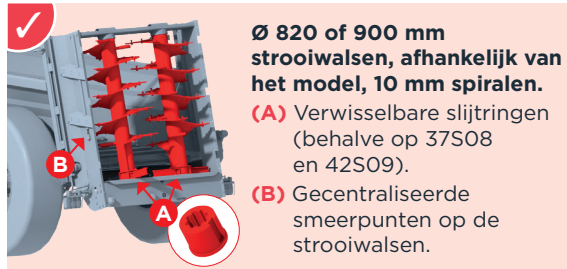

HVS STALMESTSTROOIERS

ALLE MODELLEN

HVS

evolution

- ✓ Enkelasser, van 7,8 tot 17,44 m³
- ✓ Verlaagde laadbak voor een uitstekende stabiliteit en grip op hellingen
- ✓ Uitgebalanceerde Leboulch strooiwalsen met spiralen
- ✓ Opklapbare hamers

De onderstaande afmetingen zijn in meters (m).

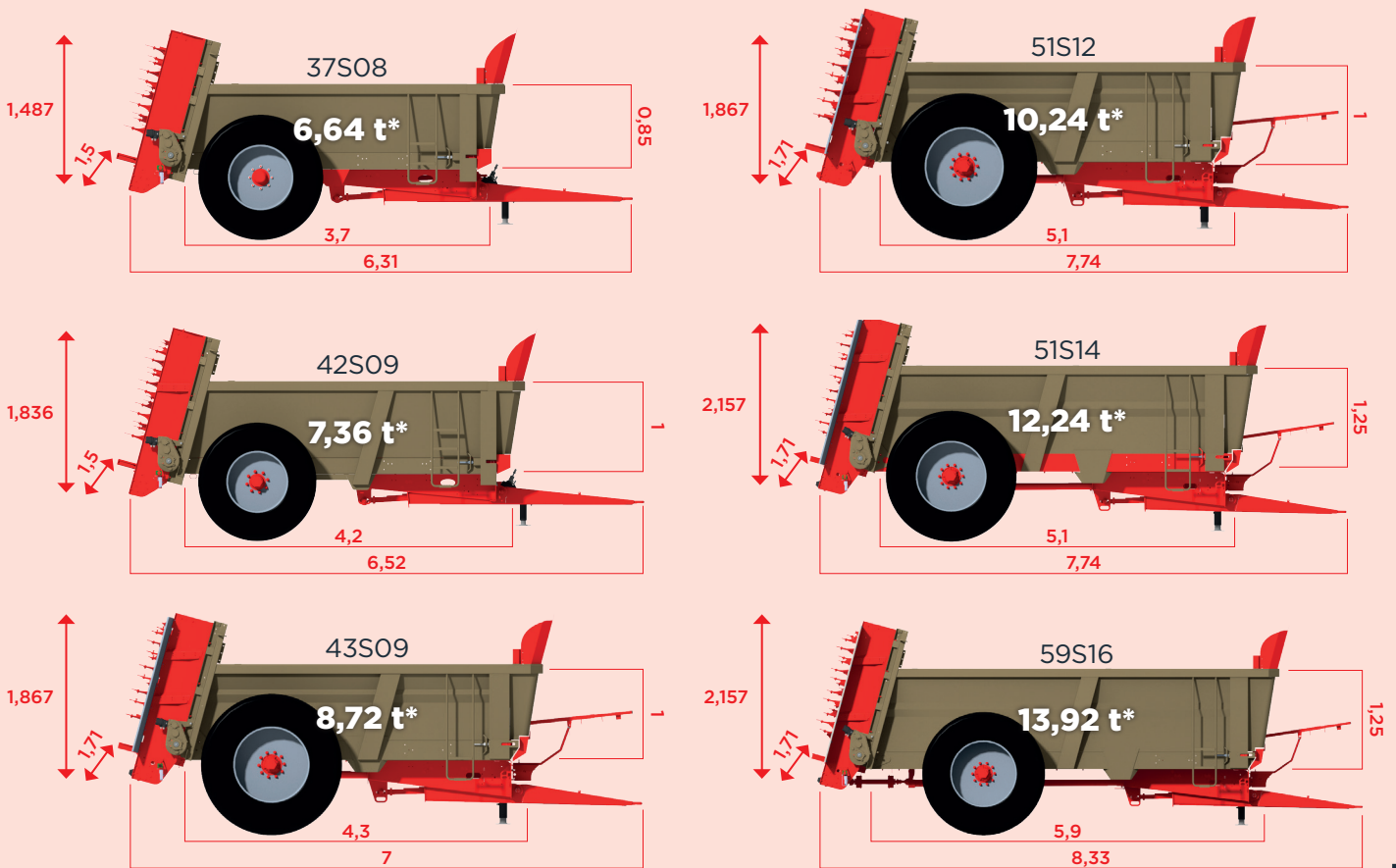

*Inhoud van stalmest met een dichtheid van 0,8 t/m³.

De namen van de modellen begrijpen:

- De eerste 2 cijfers komen overeen met de lengte van de laadbak tot de deur (in dm).
 - De letter geeft het aantal assen aan: S = enkele as.
 - De laatste 2 cijfers geven het volume stalmest aan (in m³ zonder opzetschotten).
- Voorbeeld: het model 37S08 komt overeen met een strooier met een laadbak van 3,7 m lang tot aan de deur, één as en een volume van ca. 8 m³ zonder opzetschotten.

leboulch

JLB leboulch

Route de Guernanville, 27330 La Vieille-Lyre (Frankrijk)

Tel.: +33 2 32 30 67 47

E-mail: info@leboulch.com

www.leboulch.com

